

1100 Series 1104C-44T Diesel Engine – Industrial Open Power Unit

74.5 kW / 100 hp

The Perkins® 1100 Series family of IOPU engines boasts unsurpassed productivity levels.

By combining the market leading 1100 Series engine with a matched cooling and air filtration pocket, Perkins is confident that our engines will meet increasing customer demands. The new 1100 Series range provides customers with a compact and self-contained engine package, that optimises performance and maximises value.

Perkins has transformed the threat of new emission laws into the opportunity to develop an engine with improved performance and reliability. Not only does the 1104 comply to U.S. EPA Tier 2 and EU Stage II off-highway emissions legislation, it also exceeds customer expectations on performance. Perkins has consequently created a unique, customer inspired engine family which is undoubtedly a benchmark within the diesel engine market.



| Specification | | |
|----------------------------|------------------------------------|---------------------|
| Number of cylinders | 4 in-line | |
| Bore and stroke | 105 x 127 mm | 4.1 x 5.0 in |
| Displacement | 4.41 litres | 269 in ³ |
| Aspiration | Turbocharged | |
| Cycle | 4 stroke | |
| Combustion system | Direct injection | |
| Compression ratio | 18.23:1 | |
| Rotation | Anti-clockwise, viewed on flywheel | |
| Total lubricating capacity | 8.4 litres | 2.2 US gal |
| Cooling system | Pressurised coolant | |
| Total coolant capacity | 15 litres | 4.0 US gal |

www.perkins.com

Photographs are for illustrative purposes only and may not reflect final specification. All information in this document is substantially correct at time of printing and may be altered subsequently. Final weight and dimensions will depend on completed specification.

Publication No. PN1736/11/15 Produced in England ©2014 Perkins Engines Company Limited

 **Perkins®**

THE HEART OF EVERY GREAT MACHINE

1100 Series 1104C-44T Diesel Engine – Industrial Open Power Unit

74.5 kW / 100 hp

Features and benefits

Class leading performance

- The 1104C-44T boasts an even higher torque capacity than its successful predecessor. An impressive low speed torque of over 400 Nm is available to deliver improved machine response

Cleaner and quieter

- Extensive combustion research has resulted in an engine which operates with smoke levels barely visible to the naked eye. Perkins innovative Eco-filtration system provides high quality construction with a re-usable canister, a disposable inner element and a simpler service process. Developments in numerous individual components such as a new cylinder block design and alterations to the front end gear train have resulted in reduced noise levels throughout the engine's complete operating range. An improvement of up to 3dBA in bare engine noise over its predecessor

Quality by design

- Improvements to all aspects of engine production: from concept through to manufacturing, has resulted in a higher level of engine performance, enhanced reliability and greater durability. This combined with extensive investigation into manufacturing processes has simplified sub-assemblies and improved joint and sealing technology

Ease of installation

- Design considerations to minimise installation issues provide easy and efficient engine replacement through the carryover of the existing envelope size and mounting points. The addition of a matched radiator to the IOPU engine package allows the engine to run at its optimum performance level

Lower operating costs

- Service intervals have doubled and are now set at 500 hours as standard
- **Warranties and Service Contracts**

We provide one-year warranties for constant speed engines and two-year warranties for variable speed models, as standard. These are supported by multilevel Extended Service Contracts that can be bought additionally

Discover more: www.perkins.esc

Product support

- Perkins actively pursues product support excellence by ensuring our distribution network invest in their territory – strengthening relationships and providing more value to you, our customer
- Through an experienced global network of distributors and dealers, fully trained engine experts deliver total service support around the clock, 365 days a year. They have a comprehensive suite of web based tools at their fingertips covering technical information, parts identification and ordering systems, all dedicated to maximising the productivity of your engine
- Throughout the entire life of a Perkins engine, we provide access to genuine OE specification parts and service. We give 100% reassurance that you receive the very best in terms of quality for lowest possible cost .. wherever your Perkins powered machine is operating in the world
- To find your local distributor: www.perkins.com/distributor

www.perkins.com

Photographs are for illustrative purposes only and may not reflect final specification.
All information in this document is substantially correct at time of printing and may be altered subsequently.
Final weight and dimensions will depend on completed specification.

Publication No. PN1736/11/15 Produced in England ©2014 Perkins Engines Company Limited

 **Perkins**[®]

THE HEART OF EVERY GREAT MACHINE

1100 Series 1104C-44T Diesel Engine – Industrial Open Power Unit

74.5 kW / 100 hp

Technical information

- Cast iron engine block
- Flywheel housing SAE3
- Flywheel
- Ecoplus fuel filter
- Spin-on oil filter
- Glow plug starting aid
- 12 or 24 volt alternator
- 12 or 24 volt starter motor
- LHS PTOs – 142 Nm
- Puller or pusher fans
- Radiator
- Lub oil sump steel, flat-bottomed with dipstick on left-hand side
- Balancer or non-balancer
- Integral Inlet manifold
- Gear driven coolant pump
- Oil filler – middle of top cover

Option groups

In order to meet the varying demands of our individual customers, Perkins provide a wide selection of optional items. These enable companies to produce a customised end product, precisely matched to their needs.

www.perkins.com

Photographs are for illustrative purposes only and may not reflect final specification.
All information in this document is substantially correct at time of printing and may be altered subsequently.
Final weight and dimensions will depend on completed specification.

Publication No. PN1736/11/15 Produced in England ©2014 Perkins Engines Company Limited

 **Perkins**[®]

THE HEART OF EVERY GREAT MACHINE

1100 Series 1104C-44T Diesel Engine – Industrial Open Power Unit

74.5 kW / 100 hp

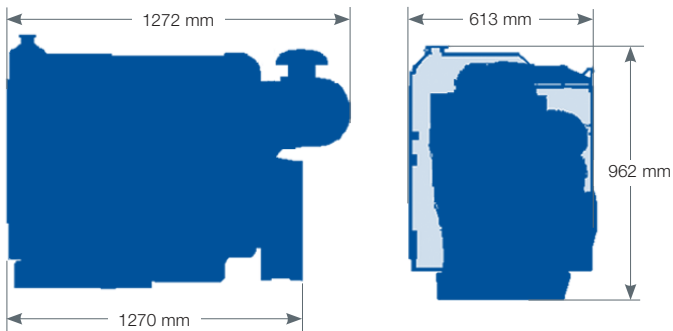

Engine package weights and dimensions

| Engine package weights and dimensions | | |
|---------------------------------------|---------|---------|
| Length | 1272 mm | 50.0 in |
| Width | 613 mm | 24.1 in |
| Height | 962 mm | 37.9 in |
| Weight (dry) | 485 kg | 1069 lb |

www.perkins.com

Photographs are for illustrative purposes only and may not reflect final specification. All information in this document is substantially correct at time of printing and may be altered subsequently. Final weight and dimensions will depend on completed specification.

Publication No. PN1736/11/15 Produced in England ©2014 Perkins Engines Company Limited

 **Perkins**[®]

THE HEART OF EVERY GREAT MACHINE

1100 Series 1104C-44T Diesel Engine – Industrial Open Power Unit

74.5 kW / 100 hp

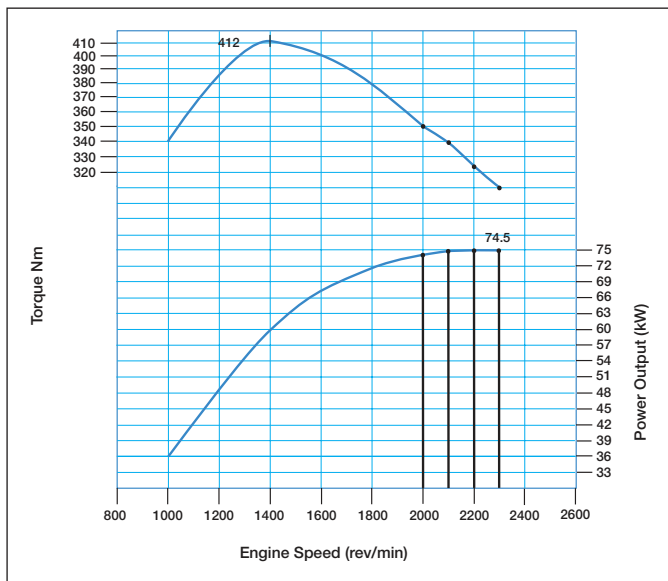

Lower speed ratings may not be read from this curve
For other ratings consult Perkins Engines Company

| Engine performance | Net intermittent | Speed rpm | Net continuous | Speed rpm |
|---------------------|------------------|-----------|----------------|-----------|
| Max power (kW) | 74.5 | 2300 | 67 | 2400 |
| Max power (hp) | 100.0 | 2300 | 90 | 2400 |
| Max torque (Nm) | 412.0 | 1400 | 371 | 1400 |
| Max torque (lbf·ft) | 306.0 | 1400 | 274 | 1400 |

Power for a run-in engine after 60 hours
Rating standard ISO/TR 14396

www.perkins.com

Photographs are for illustrative purposes only and may not reflect final specification.
All information in this document is substantially correct at time of printing and may be altered subsequently.
Final weight and dimensions will depend on completed specification.

Publication No. PN1736/11/15 Produced in England ©2014 Perkins Engines Company Limited

 **Perkins**[®]

THE HEART OF EVERY GREAT MACHINE