

# 400 Series 404D-22T Industrial

45.5 kW / 61 hp @ 3000 rpm

The Perkins 400D range has been developed in consultation with our marketplace. This 2.2 Litre, 4 cylinder, turbocharged engine complements the exciting 400 Series product line-up, offering customers a choice of compact, lightweight power units whilst maintaining all the customer benefits they can experience from other products in the range.

The 400 Series engine family continues to set new standards in the compact engine market. Developed alongside customers to fulfil their needs in the construction, materials handling, agricultural/turf, genset and compressor markets, it is another class leading diesel range from Perkins.

Long 500 hour service intervals, a two-year standard warranty, low noise and harshness, and a wide range of options make the 400 Series range the complete solution for compact power needs.

The 404D-22T is a powerful but quiet 2.2 litre turbocharged unit delivering impressive performance with low operating costs in a small efficient package ideal for a range of off-highway applications.



Specification		
Number of cylinders	4 in-line	
Bore and stroke	84 x 100 mm	3.3 x 3.9 in
Displacement	2.2 litres	135 in <sup>3</sup>
Aspiration	Turbocharged	
Cycle	4 stroke	
Combustion system	Indirect injection	
Compression ratio	23:3:1	
Rotation	Anti-clockwise, viewed on flywheel	
Total lubricating capacity	10.6 litres	2.8 US gal
Cooling system	Liquid	
Total coolant capacity	8.9 litres	2.3 US gal

[www.perkins.com](http://www.perkins.com)

Photographs are for illustrative purposes only and may not reflect final specification. All information in this document is substantially correct at time of printing and may be altered subsequently. Final weight and dimensions will depend on completed specification.

Publication No. PN1820/12/14 Produced in England ©2014 Perkins Engines Company Limited

 **Perkins**<sup>®</sup>

THE HEART OF EVERY GREAT MACHINE

# 400 Series 404D-22T Industrial

45.5 kW / 61 hp @ 3000 rpm

## Features and benefits

### Ultra-compact power

- The neatly installed side mounted turbocharger position provides additional power with minimum impact on package size making fitment into machines easier
- Up to 45.5 kW (61 bhp) from an engine envelope of 0.25 m<sup>3</sup> (8.8 ft<sup>3</sup>)

### Clean and quiet

- Noise levels have been kept to a minimum
- Subjective harshness has been carefully controlled making the engine sound even quieter

### Durable power

- Product design and process improvements enhance both engine reliability and durability
- An improved governor and new compliance testing deliver reliability of 6,000 hours
- A standard two-year warranty demonstrates our confidence in durability and reliability

### Low operating costs

- Approved for operation on biodiesel\* concentrations of up to 20%
- Oil and filter changes are 500 hours, dependent on load factor
- Engine durability and reliability, the warranty offering, and ease of installation combine to drive down the cost of ownership
- **Warranties and Service Contracts**

We provide one-year warranties for constant speed engines and two-year warranties for variable speed models, as standard. These are supported by multilevel Extended Service Contracts that can be bought additionally  
Discover more: [www.perkins.esc](http://www.perkins.esc)

### Product support

- With highly trained Perkins distributors in thousands of communities in over 180 countries, you are never far away from expert product knowledge, genuine parts and a range of advanced diagnostic technology for keeping your engine in peak condition
- To find your local distributor: [www.perkins.com/distributor](http://www.perkins.com/distributor)

\*Subject to conformance with ASTM D6751 and EN14214

[www.perkins.com](http://www.perkins.com)

Photographs are for illustrative purposes only and may not reflect final specification.  
All information in this document is substantially correct at time of printing and may be altered subsequently.  
Final weight and dimensions will depend on completed specification.

Publication No. PN1820/12/14 Produced in England ©2014 Perkins Engines Company Limited

 **Perkins**<sup>®</sup>

THE HEART OF EVERY GREAT MACHINE

# 400 Series 404D-22T Industrial

45.5 kW / 61 hp @ 3000 rpm

## Technical information

- Cast iron engine block
- Flywheel and flywheel housing
- Fuel injection pump
- Flywheel and flywheel housing
- Fuel injection pump
- Glow plug starting aid
- Lub oil sump
- Spin on lub oil filter
- Inlet manifold
- Cast iron exhaust manifold – side outlet
- Coolant pump belt driven
- Choice of cooling fans
- Starter motor 12 volt and 24 volt
- Alternator 12 volt and 6.5 amp
- ESOS (Electric shut-off solenoid)
- Lub oil pressure switch
- Coolant temperature switch
- SAE A PTO
- High and low fan positions
- Electronic controlled governing as an option

## Option groups

A selection of optional items is available to enable you to prepare a specification precisely matched to your needs.

[www.perkins.com](http://www.perkins.com)

Photographs are for illustrative purposes only and may not reflect final specification.  
All information in this document is substantially correct at time of printing and may be altered subsequently.  
Final weight and dimensions will depend on completed specification.

Publication No. PN1820/12/14 Produced in England ©2014 Perkins Engines Company Limited

 **Perkins**<sup>®</sup>

THE HEART OF EVERY GREAT MACHINE

# 400 Series 404D-22T Industrial

45.5 kW / 61 hp @ 3000 rpm

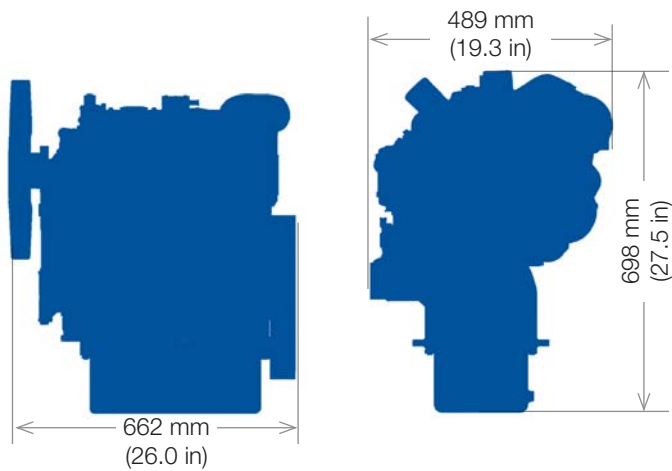

Engine package weights and dimensions

Engine package weights and dimensions		
Length	662 mm	26.0 in
Width	489 mm	19.3 in
Height	698 mm	27.5 in
Weight (dry)	194 kg	428 lb

[www.perkins.com](http://www.perkins.com)

Photographs are for illustrative purposes only and may not reflect final specification.  
All information in this document is substantially correct at time of printing and may be altered subsequently.  
Final weight and dimensions will depend on completed specification.

Publication No. PN1820/12/14 Produced in England ©2014 Perkins Engines Company Limited

 **Perkins**<sup>®</sup>

THE HEART OF EVERY GREAT MACHINE

# 400 Series 404D-22T Industrial

45.5 kW / 61 hp @ 3000 rpm

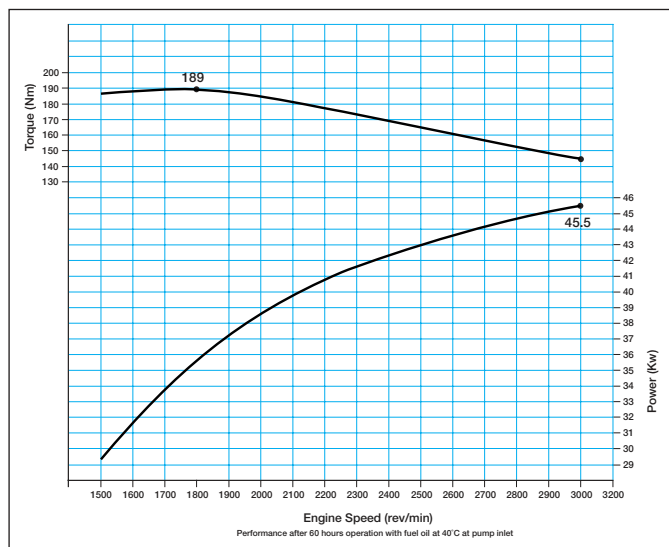

Performance data	Gross power	Speed rpm
Power output (kW)	45.5	3000
Power output (hp)	61.0	3000
Peak torque (Nm)	189.0	1800
Peak torque (lbf·ft)	139.5	1800

Power output for a run-in engine after 60 hours

[www.perkins.com](http://www.perkins.com)

Photographs are for illustrative purposes only and may not reflect final specification. All information in this document is substantially correct at time of printing and may be altered subsequently. Final weight and dimensions will depend on completed specification.

Publication No. PN1820/12/14 Produced in England ©2014 Perkins Engines Company Limited

 **Perkins**®

THE HEART OF EVERY GREAT MACHINE