

# 2800 Series 2806D-E18TA/TTA Industrial Engine

EU Stage IIIA, U.S. EPA Tier 3  
429-597 kW / 575-800 hp

The ability to power your machine line-up with one engine supplier is truly achievable with Perkins. We have introduced a platform of 9-18 litre industrial engines that completes our market-leading industrial power range and covers 8.8-597 kW (11.8-800 hp).

This model is a turbocharged, air-to-air chargecooled, 18.1 litre, 6 cylinder product capable of producing 597 kW (800 hp).

The exceptional power density and reliability of these engines make them an ideal choice for applications operating in countries that meet equivalent Stage IIIA/ Tier 3 and China III emissions standards.

To support the demands of your machine installation we offer a choice of engine configurations and options. The robust technology allows you to integrate these engines into your equipment with the minimum of re-engineering.

Perkins has developed a reputation for designing and building reliable and durable engines for the most demanding applications. Choosing Perkins as your engine supplier means your development costs can be reduced and your machines are future-proofed to meet anticipated emissions standards.

Designed to meet EU Stage IIIA and U.S. EPA Tier 3 equivalent emissions standards.

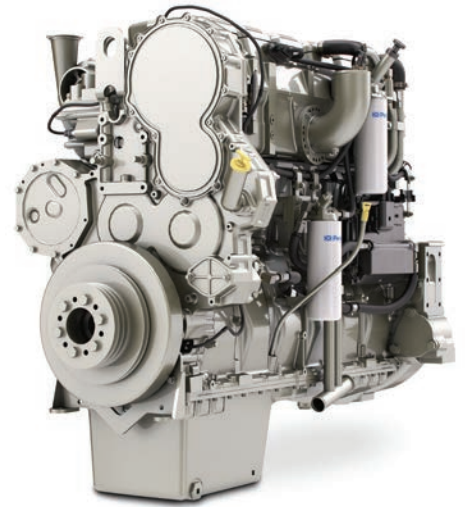

| Specification              |                                    |                 |
|----------------------------|------------------------------------|-----------------|
| Number of cylinders        | 6 vertical in-line                 |                 |
| Bore and stroke            | 145 x 183 mm                       | 5.7 x 7.2 in    |
| Displacement               | 18.1 litres                        | 1104.5 cubic in |
| Aspiration                 | Turbocharged aftercooled           |                 |
| Cycle                      | 4 stroke                           |                 |
| Combustion system          | Direct injection                   |                 |
| Compression ratio          | 16.3:1                             |                 |
| Rotation                   | Anti-clockwise, viewed on flywheel |                 |
| Total lubricating capacity | 40-72 litres                       | 10.5-19 US gal  |
| Cooling system             | Liquid                             |                 |

[www.perkins.com](http://www.perkins.com)

Photographs are for illustrative purposes only and may not reflect final specification.  
All information in this document is substantially correct at time of printing and may be altered subsequently.  
Final weight and dimensions will depend on completed specification.

Publication No. PN3119/04/16 Produced in England ©2016 Perkins Engines Company Limited

 **Perkins**<sup>®</sup>

THE HEART OF EVERY GREAT MACHINE

# 2800 Series 2806D-E18TA/TTA Industrial Engine

EU Stage IIIA, U.S. EPA Tier 3  
429-597 kW / 575-800 hp

## Features and benefits

### Dependable power

- World-class manufacturing capability and processes coupled with proven core engine designs assure reliability, quiet operation and many hours of productive life

### High performance

- Simple and efficient turbocharger or series turbocharger\*\* provides optimal air management and improved fuel efficiency

### Lifetime of low cost

- Fuel consumption optimised to match operating cycles of a wide range of equipment and applications.
- Capability of 500 hour oil change intervals enables low-cost maintenance

### Fuel and oil

- Approved for operation on biodiesel\* concentrations of up to 20%\*

### Package size

- Exceptional power density enables standardisation across numerous applications. Multiple installation options available to minimize total package size

### Local support, global coverage

- Perkins recognise that the customer relationship is important to machine manufacturers and we can offer a range of flexible solutions to help provide appropriate support, either to the OEM's network or directly to the machine customer
- With highly trained Perkins distributors in thousands of communities in over 180 countries, you are never far away from expert product knowledge, genuine parts and a range of advanced diagnostic technology for keeping your engine in peak condition
- To find your local distributor: [www.perkins.com/distributor](http://www.perkins.com/distributor)

\*Subject to conformance with ASTM D6751 and EN14214

\*\* Series turbocharger configuration only available on specific ratings.

\*\* Series turbocharger configuration only available on specific ratings.

[www.perkins.com](http://www.perkins.com)

Photographs are for illustrative purposes only and may not reflect final specification.  
All information in this document is substantially correct at time of printing and may be altered subsequently.  
Final weight and dimensions will depend on completed specification.

Publication No. PN3119/04/16 Produced in England ©2016 Perkins Engines Company Limited

 **Perkins**<sup>®</sup>

THE HEART OF EVERY GREAT MACHINE

# 2800 Series 2806D-E18TA/TTA Industrial Engine

EU Stage IIIA, U.S. EPA Tier 3  
429-597 kW / 575-800 hp

## Technical information

### Air inlet

- Turbocharged aftercooled
- Single or Series\*\* configurations

### Control system

- Full electronic control system
- All connectors and wiring looms waterproof and designed to withstand harsh off-highway environments
- Flexible and configurable software features and well supported SAE J1939 CAN bus enables highly integrated machines

### Cooling system

- Vertical outlet thermostat housing, centrifugal water pump
- Detailed guidance on cooling system design and validation available to ensure machine reliability

### Flywheel and housing

- Wide choice of drivetrain interfaces, SAE0 and SAE1 configurations

### Fuel and fuel system

- Mechanical Unit Injector Fuel system, controlled electronically

### Oil system

- Choice of sumps for different applications
- Open crankcase ventilation system with fumes disposal (optional OCV filter system)
- Oil cooler, oil filler, oil filter, oil dipstick, oil pump (gear-driven)

### Power take-off

- SAE1 power take-off available with optional SAE A, SAE B and SAE C power take-off drives
- Engine power can also be taken from the front of the engine on some applications

\*\* Series turbocharger configuration only available on specific ratings.

[www.perkins.com](http://www.perkins.com)

Photographs are for illustrative purposes only and may not reflect final specification.  
All information in this document is substantially correct at time of printing and may be altered subsequently.  
Final weight and dimensions will depend on completed specification.

Publication No. PN3119/04/16 Produced in England ©2016 Perkins Engines Company Limited

 **Perkins**<sup>®</sup>

THE HEART OF EVERY GREAT MACHINE

# 2800 Series 2806D-E18TA/TTA Industrial Engine

EU Stage IIIA, U.S. EPA Tier 3  
429-597 kW / 575-800 hp

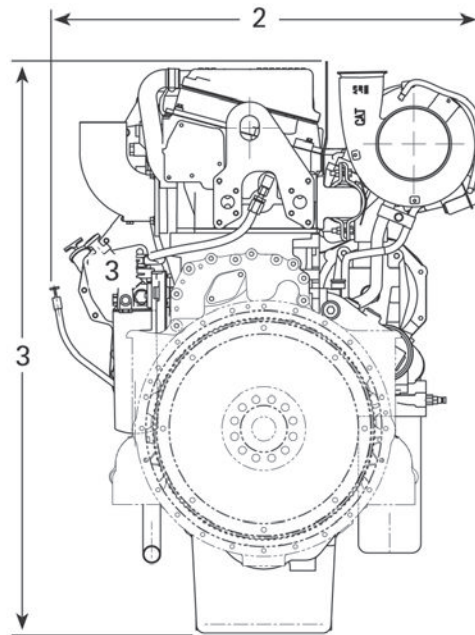
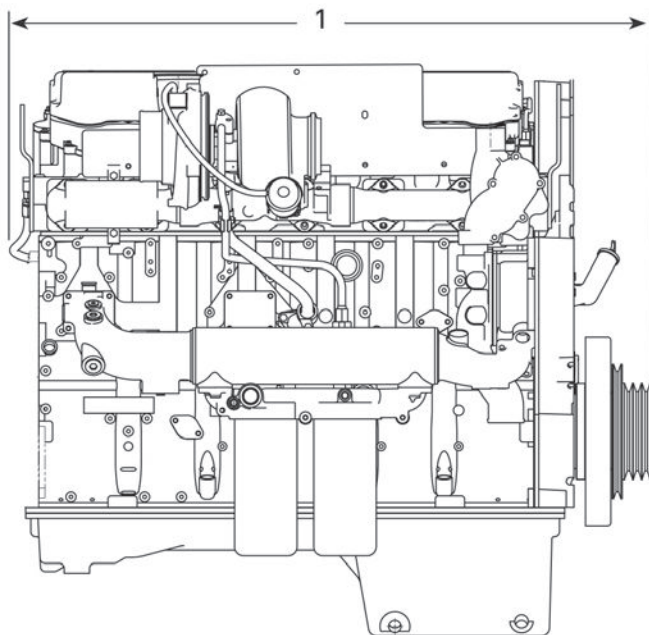

Engine package dimensions and weight

|   |        |           |         |
|---|--------|-----------|---------|
| 1 | Length | 1392.1 mm | 54.8 in |
| 2 | Width  | 939.5 mm  | 37.0 in |
| 3 | Height | 1241.5 mm | 48.9 in |
|   | Weight | 1673 kg   | 3688 lb |

[www.perkins.com](http://www.perkins.com)

Photographs are for illustrative purposes only and may not reflect final specification.  
All information in this document is substantially correct at time of printing and may be altered subsequently.  
Final weight and dimensions will depend on completed specification.

Publication No. PN3119/04/16 Produced in England ©2016 Perkins Engines Company Limited

 **Perkins**<sup>®</sup>

THE HEART OF EVERY GREAT MACHINE

# 2800 Series 2806D-E18TA/TTA Industrial Engine

EU Stage IIIA, U.S. EPA Tier 3  
429-597 kW / 575-800 hp

## TA Ratings Curve

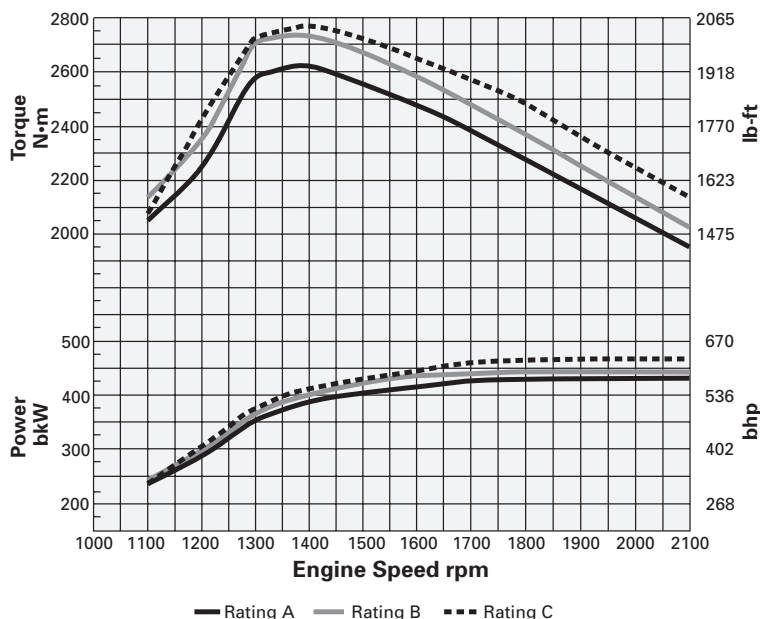

| Aspiration | Speed rpm | Power kW | Power hp | Speed rpm | Torque Nm | Torque lb-ft | Rating type |
|------------|-----------|----------|----------|-----------|-----------|--------------|-------------|
| TA         | 2100      | 429      | 575      | 1400      | 2627      | 1938         | A           |
| TA         | 2100      | 447      | 600      | 1400      | 2742      | 2022         | B           |
| TA         | 2100      | 470      | 630      | 1400      | 2769      | 2043         | C           |
| TTA        | 2100      | 571      | 765      | 1400      | 3496      | 2579         | D           |
| TTA        | 2100      | 597      | 800      | 1400      | 3656      | 2697         | E           |

## Rating definitions and conditions

**IND-A (Continuous)** for heavy duty service where the engine is operated at maximum power and speed up to 100% of the time without interruption or load cycling.

**IND-B** for service where power and/or speed are cyclic (time at full load not to exceed 80%).

**IND-C (Intermittent)** is the horsepower and speed capability of the engine where maximum power and/or speed are cyclic (time at full load not to exceed 50%).

**IND-D** for service where maximum power is required for periodic overloads (time at full load not to exceed 10% of the duty cycle).

**IND-E** for service where maximum power is required for a short time for initial starting or sudden overload. For emergency service where standard power is unavailable (time at full load not to exceed 5% of the duty cycle).

### Rating Conditions for Diesel Engines – 7 litre and higher

All rating conditions are based on SAE J1995, inlet air standard conditions of 99 kPa (29.31 in. Hg) dry barometer and 25°C (77°F) temperature. Performance is measured using a standard fuel with fuel gravity of 35° API having a lower heating value of 42,780 kJ/kg (18,390 btu/lb) when used at 29°C (84.2°F) with a density of 838.9 g/L.

www.perkins.com

Photographs are for illustrative purposes only and may not reflect final specification. All information in this document is substantially correct at time of printing and may be altered subsequently. Final weight and dimensions will depend on completed specification.

Publication No. PN3119/04/16 Produced in England ©2016 Perkins Engines Company Limited



THE HEART OF EVERY GREAT MACHINE